

## HYBRID INDUSTRIAL ROBOT COMPLIANT MOTION CONTROL

*UDC 681.5.01*

**Žarko M. Čojbašić, Vlastimir D. Nikolić**

Mechanical Engineering Faculty, University of Niš  
E-Mail: zcojba@ni.ac.yu

**Abstract.** *This paper presents novel simple and computationally efficient control schemes for achieving efficient interaction between the manipulator and its environment. Proposed adaptive neuro-fuzzy-genetic control schemes for explicit force robot control are based on fuzzy adaptation empowered conventional model-based impedance control of industrial robots. Simulation and control laboratory experiments performed on a real-scale six degree-of-freedom industrial robot are presented to demonstrate the performance of the proposed computationally intelligent impedance control approaches.*

**Key words:** *robotics, impedance control, constrained motion, computational intelligence, neuro-fuzzy-genetic control*

### 1. INTRODUCTION

Impedance control, which has evolved from a seminal theoretical concept [1] to space research and industrial implementation stage [2], provides a reliable unified approach for controlling robots in both free-space and during contact with the environment.

However, a major shortcoming of the impedance control is the inability to control interaction forces. In practice, contact force can be indirectly regulated by selecting the nominal motion and target impedance parameters in accordance to environment, but it is usually unknown. Next critical issue is the requirement for the stable bounceless contact transition, which imposes a significantly overdamped impedance behavior to ensure a stable contact with stiff uncertain environment [3]. This causes a sluggish robot response resulting in higher impact and velocity proportional forces during transition. Significant research efforts have recently been addressed towards overcoming these drawbacks [4]. The majority of the proposed approaches utilized adaptive control methods, but they suffer from several limitations.

The aim of this paper is to present more reliable approaches for the adaptation of target impedance parameters, retaining simple impedance control structure and utilizing the

experience and understanding impedance control behavior. An effective way to achieve this was to propose computationally intelligent adaptation schemes, extending and comparing the ideas published in [7][8][11][12][13][15].

More specifically, hybrid control approaches considered in the paper are based on fuzzy and neuro-fuzzy-genetic adaptation of the impedance control loops. Also, the implementation of fuzzy systems using neural networks was used, which provides for trainable neuro-fuzzy structure that can benefit from both qualitative and quantitative available information. Besides, several computationally intelligent concepts are applied for control systems structure determination and optimization [11][14].

The performance of designed computationally intelligent impedance control systems is demonstrated by simulation and compared with classical impedance control experiments with an industrial robot (Manutec r3).

## 2. CONVENTIONAL POSITION BASED IMPEDANCE CONTROL

In commercially applied robotic systems it is most promising to implement position based compliance control schemes by closing force sensing-loops around the stable and robust position controller [2]. If  $\mathbf{G}_r(s)$  and  $\mathbf{G}_s(s)$  are transfer matrices of the regulator and robotic plant respectively, the closed-loop behavior of the robot arm in contact with a working environment (Fig. 1) can be expressed as

$$\begin{aligned} \mathbf{x} &= \mathbf{G}_{pE}(s)\mathbf{x}_0 + \mathbf{G}_{xE}(s)\mathbf{x}_E, \quad \mathbf{G}_{pE}(s) = [\mathbf{G}_s(s)^{-1} + \mathbf{G}_r(s) + \mathbf{G}_E(s)]^{-1} \mathbf{G}_r(s), \\ \mathbf{G}_{xE}(s) &= [\mathbf{G}_s(s)^{-1} + \mathbf{G}_r(s) + \mathbf{G}_E(s)]^{-1} \mathbf{G}_E(s). \end{aligned} \quad (1)$$

In impedance control the relationship between end-effector acting force and the error between nominal and actual positions of end-effector is controlled according to the law

$$-\mathbf{F} = \mathbf{M}_t \ddot{\mathbf{e}} + \mathbf{B}_t \dot{\mathbf{e}} + \mathbf{K}_t \mathbf{e}, \quad (2)$$

where  $\mathbf{e} = \mathbf{x}_0 - \mathbf{x}$  is position error,  $\mathbf{M}_t$  and  $\mathbf{B}_t$  and  $\mathbf{K}_t$  are positive definite diagonal inertia, damping and stiffness matrices, which define the target impedance model.

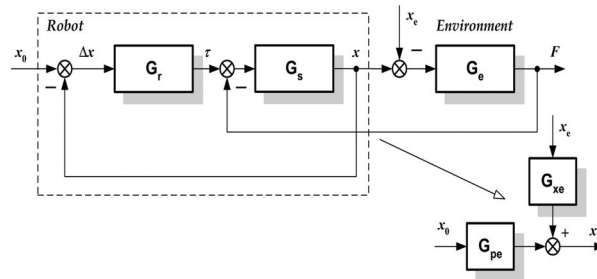

Fig. 1. Position control system in contact with environment

The basic impedance control scheme is depicted in Fig. 2. This scheme consists of two control loops: an inner position servo and an outer loop generating position command

modification  $\Delta x_F$  based on end effector force/torque measurements. The outer loop is naturally closed when the end-effector encounters the environment.

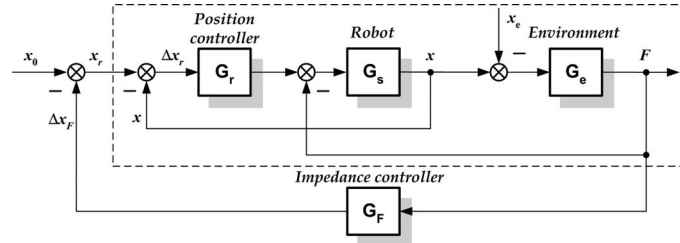

Fig. 2. Basic impedance control scheme

The entire impedance control design problem is split into two sub-problems: realization of target impedance model, and choice of target impedance parameters to meet a stable interaction with environment and required performance. It is useful to express the force in terms of nominal penetration

$$\mathbf{F}(s) = [\mathbf{G}_r(s)^{-1} + \mathbf{G}_e(s)^{-1}]^{-1} \mathbf{G}_p(s) \mathbf{p}_0(s) = \mathbf{Z}_c(s) \mathbf{p}_0(s), \quad (3)$$

where the dimension and physical meaning of the transfer function corresponds to an impedance referred to as coupled impedance. It represents a serial connection of target impedance and environmental impedance, which is filtered through the closed loop position control function.

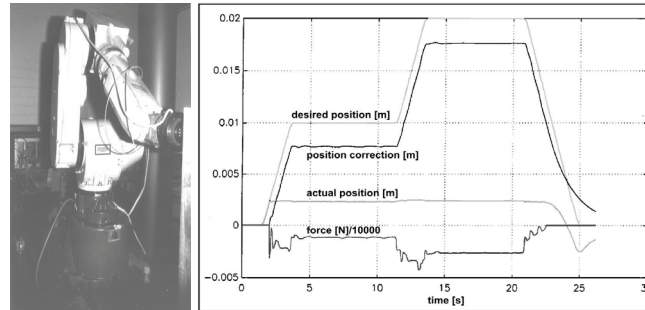

Fig. 3. Experimental system and measurements  
( $M_t=20$  kg,  $\xi_t=8$ ,  $K_t=1500$  N/m,  $K_e=157000$  N/m)

A practical contact stability condition has been established in [3] on the simple geometric consideration. High damping required to stabilize the transition process with delayed force signals causes sluggish behavior, high impact forces and force overshoots. A typical transition experiment with a Manutech r3 robot is presented in Fig. 3. As working object, a cantilever beam with a variable cross-section is used and nominal goal position beyond the contacted surface is commanded.

## 3. IMPEDANCE CONTROL WITH FUZZY ADAPTATION: THE FIRST APPROACH

We have designed a fuzzy controller in order to adapt the target model parameters ( $\xi_t$  and  $K_t$ ), with 3 goals:

- to enhance contact transition stability in critical phases of the robot compliant motion,
- to improve force transition performance (reduce overshoots) and
- to achieve a desired steady-state force independent on nominal penetration and environmental stiffness.

Proposed control scheme consists of 3 components (Fig. 4): position control loop, impedance controller that adjusts it, and a fuzzy adaptation mechanism that modifies impedance controller according to the difference between the actual and desired force responses.

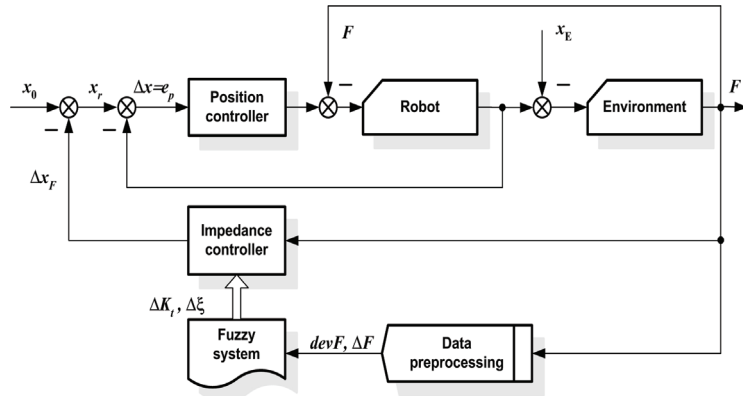

Fig. 4. Block diagram of the first proposed control scheme

First input of the fuzzy adaptation mechanism is contact force deviation  $devF(k) = F_d - F(k)$ , i.e. deviation of force from the desired steady state force  $F_d$ . This input has been multiplied by contact flag ( $|\text{sign } F|$ ), which indicates contact in order to prevent adaptation of impedance controller's parameters during the unconstrained motion. The second input is force increment  $\Delta F(k) = F(k) - F(k-1)$ , which is substitution for derivative. Outputs of the fuzzy controller are increments of the stiffness and damping coefficient,  $\Delta K_t$  and  $\Delta \xi$ , which provide for the direct adaptation of the impedance controller.

Fuzzy partitioning of the input and output controller variables has been performed by choosing 7 primary fuzzy sets for each variable, marked with linguistic labels that appear in the fuzzy control rules. Applied rule base consists of all 49 rules, which are shown in Table 1. Each rule is producing two decisions, for two controller outputs.

It is of the utmost importance to prevent loss of contact during transition process. Critical moment is especially when nominal velocity reduces to zero, meaning that position controller suddenly releases strong 'push forward' movement, resulting in steep decrease of the contact force.

Table 1. Rule base defining fuzzy control rules

		$devF$						
		NB	NM	NS	ZO	PS	PM	PB
$\Delta F$	$\Delta K_t$	NB	NM	NS	ZO	PS	PM	PB
	$\Delta \xi$	NB	NM	NS	ZO	PS	PM	PB
	NB	NB	NM	NS	ZO	ZO	ZO	ZO
	NM	NB	NB	NB	NB	NS	NS	ZO
	NS	NB	NM	NS	ZO	ZO	ZO	PS
	ZO	NM	NM	NM	NM	ZO	ZO	ZO
	PS	NB	NS	NS	ZO	ZO	PS	PM
	PB	NM	NM	NS	NS	ZO	ZO	NS
NB	NB	NM	NS	ZO	PS	PM	PB	
NM	NB	NM	NS	ZO	PS	PM	PB	
NS	NM	NS	ZO	ZO	PS	PM	PB	
ZO	PS	ZO	ZO	PS	PS	PM	PM	
PS	NS	ZO	ZO	ZO	PS	PM	PB	
PM	ZO	ZO	ZO	PM	PM	PM	PM	
PB	ZO	ZO	ZO	ZO	PS	PM	PB	
		ZO	PS	PS	PB	PB	PB	

Therefore the lower right corner rule of the rule base is:

$$\text{If } devF \text{ is } \mathbf{PB} \text{ and } \Delta F \text{ is } \mathbf{PB} \text{ then } \Delta K_t \text{ is } \mathbf{PXB}, \Delta \xi \text{ is } \mathbf{PXB}, \quad (4)$$

where **PXB** in the consequent part of the rule denotes newly defined fuzzy sets (**P**ositive **eX**tra **B**ig) in the domains of both output variables of the fuzzy controller, defined with membership functions allowing approximately 5 times stronger adaptation of impedance controller's parameters in described critical situation which is serviced by the rule.

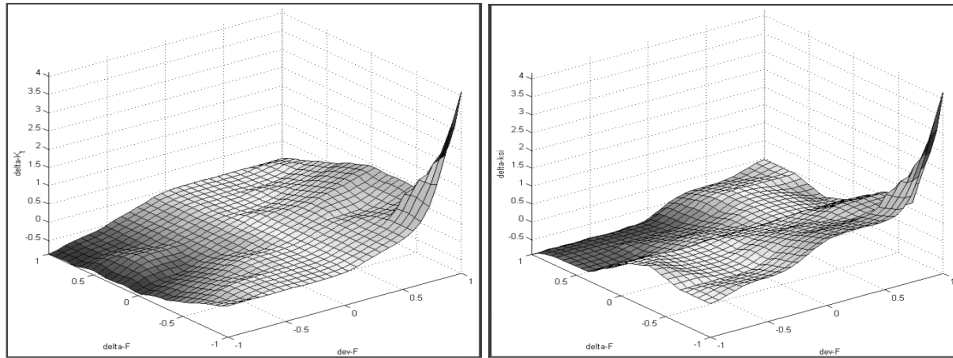

Fig. 5. Control surfaces of the fuzzy controller for both outputs

Control surfaces of the fuzzy controller are shown in Fig. 5. It is clear that the adaptation of the parameters is very strong when both inputs are reaching high positive values, while in other regions of the controller surfaces normal adaptation of the

parameters of impedance controller is performed, which is sufficient to lead system to the desired steady state.

#### 4. STABILITY ANALYSIS OUTLINE AND RESULTS

A place to start a stability analysis of the hybrid fuzzy-impedance control is ideal target impedance model. It can be assumed that the nominal trajectory  $p_0(t)$  is continuous and bounded, with initial condition  $p_0(t_0)=0$ , and  $p_0 \rightarrow p_0^*$  as  $t$  increases, where  $p_0^*$  is maximum penetration corresponding to the nominal goal position, and also that impedance parameter functions  $\xi_i(t)$  and  $\omega_i(t)$  (i.e.  $K_i$ ) are positive, bounded and continuous.

Under these circumstances, the position deviation  $e(t)$  and actual penetration  $p(t)$  reach the equilibriums

$$p^* = p_0^*/1 + \kappa^*, \quad e^* = \kappa^* \cdot p_0^*/1 + \kappa^*, \quad (5)$$

where  $\kappa^* = K_e/K_t^*$ . The interaction model can be written into an equivalent non-stationary form obtained by shifting the origins  $\bar{e} = e - e^*$ , i.e.  $\bar{p} = p - p^*$  (delay is neglected)

$$\begin{aligned} \ddot{\bar{e}}(t) + 2\xi_i(t)\omega_i(t)\dot{\bar{e}}(t) + (\omega_i^2(t) + \omega_e^2)\bar{e}(t) &= \omega_e^2(p_0(t) - \hat{p}_0^*), \\ \hat{p}_0^* &= p_0^* \cdot \kappa^*(1 + \kappa)/\kappa(1 + \kappa^*). \end{aligned} \quad (6)$$

Let us now define a Liapunov function candidate:

$$\begin{aligned} V &= 0.5 \cdot [\dot{\bar{e}}^2 + (\omega_i^2(t) + \omega_e^2)\bar{e}^2], \\ \dot{V} &= -2\xi_i(t)\omega_i(t)\dot{\bar{e}}^2 + \dot{\bar{e}}\omega_e^2(p_0 - \hat{p}_0^*) + \omega_i(t)\dot{\omega}_i(t)\bar{e}^2. \end{aligned} \quad (7)$$

These equations provide the baseline for the synthesis of stable fuzzy adaptation of impedance control parameters. Increase of the damping stabilizes the system, while the influence of target stiffness variations is much more complex.

However, the estimates of contact transition measures based on the Liapunov functions (7) might be very conservative and the practical stability can provide more useful results. When the effects of time lags and Coulomb friction are included, the stability analysis becomes much more complex.

In order to test effectiveness of the proposed control scheme, a series of simulation tests on a real-scale 6 DOF industrial robot Manutec r3 have been performed. Some of the obtained results are shown in Fig. 6, and performance has been compared to classical impedance controllers.

Attention has been paid to the system robustness against various disturbances that occur in the real robotic system: sensor noises, friction and time lag. System has proven to be insensitive to influence of the moderate sensor noises.

5. COMPUTATIONALLY INTELLIGENT IMPEDANCE CONTROL: THE SECOND APPROACH

The second proposed control scheme consists of the main components shown in Fig. 7: position control loop and a fuzzy adaptation mechanism that performs intelligent ‘blending’ of several impedance controllers, which are optimally tuned for cases of different environments that robot can interact with.

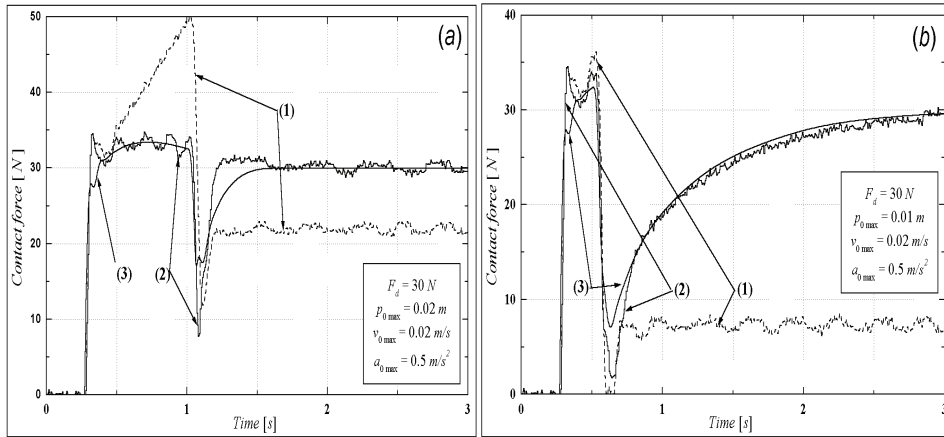

Fig. 6. Controller performance: (1) Impedance (lag + friction + noises), (2) Fuzzy adaptive impedance (lag + friction + noises), (3) Fuzzy adaptive impedance (ideal case)

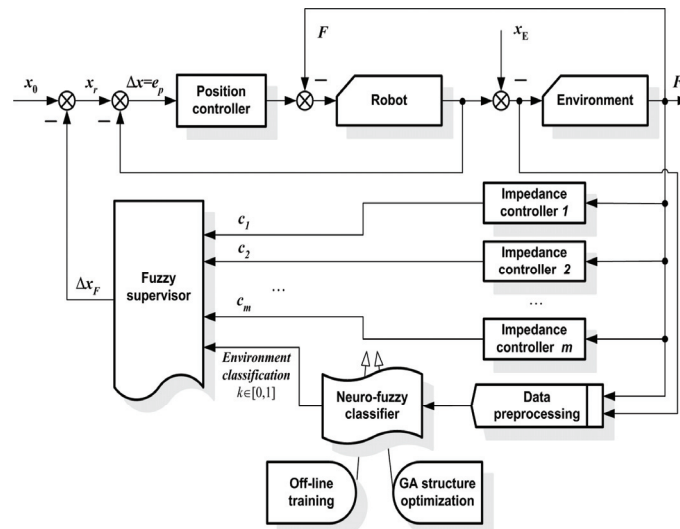

Fig. 7. Block diagram of the second proposed control scheme

Fuzzy supervisor has one decisive input, classification of the dynamic environment with which robot maintains contact. It has one output  $\Delta x_F$ , which is used as correction of

the position control loop input, just as it is the case with the conventional impedance control.

For example, for realization with  $m$  impedance controllers producing outputs  $c_1, c_2, \dots, c_m$ , implemented  $k^{\text{th}}$  fuzzy rule would be as follows:

$$\text{If (environment is } \mathbf{A}_k) \text{ then } (\Delta x_F = a_{k1} \cdot c_1 + \dots + a_{km} \cdot c_m). \quad (8)$$

In each rule, coefficients  $a_{k1}, a_{k2}, \dots, a_{km}$  are all equal to zero, except for one which is set to one.

Control algorithm from Fig. 7 demands information on the type of environment, so that fuzzy supervisor can perform intelligent selection of optimally tuned impedance controller based on it. Solution to the problem of defining the signal representing the classification of dynamic environment is based on the ideas from [9][10]. Unlike those papers, neuro-fuzzy classifier is proposed for environment classification. Application is performed in two phases: the first, which involves off-line identification of the structure of neuro-fuzzy network and its training, and the second phase, which involves on-line classification of environment. Inputs to neuro-fuzzy environment classifier are deforming position, deforming velocity and deforming acceleration as well as contact force.

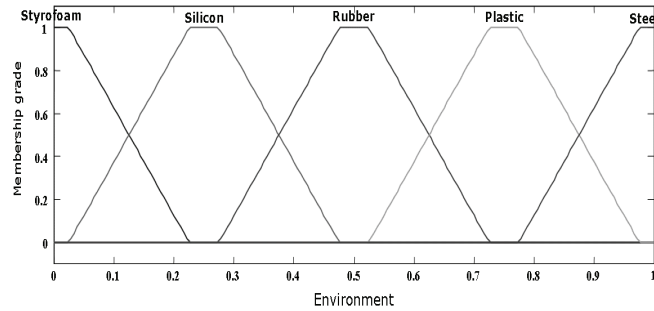

Fig. 8. Fuzzy partitioning of decisive input variable 'environment'

Other combinations of inputs are possible [10], but proposed version provides for practically instantaneous classification of the environment in application phase [9].

Table 2 Inputs and target outputs for nf classifier

Input variables for neuro-fuzzy classifier	Target outputs of neuro-fuzzy classifier
<i>Force F</i>	<i>Styrofoam – 0.00</i>
<i>Deforming position <math>\Delta x</math></i>	<i>Silicon – 0.25</i>
<i>Deforming velocity <math>\Delta \dot{x}</math></i>	<i>Rubber – 0.5</i>
<i>Deforming acceleration <math>\Delta \ddot{x}</math></i>	<i>Plastic – 0.75</i>
	<i>Steel - 1</i>



Data for training neuro-fuzzy classifier have been experimentally collected. Input variables and target outputs for some environments are shown in Table 2. Target outputs of neuro-fuzzy classifier for different environments are chosen to be equidistant values from interval  $[0,1]$ , which provides for the efficient application in the application phase.

Efficient ANFIS neuro-fuzzy structure with hybrid BP/RLSE training algorithm [5] has been used for training of classifier, while its structure has been optimized by means of real-coded genetic algorithm [6].

## 6. COMPUTATIONALLY INTELLIGENT IMPEDANCE CONTROL: THE THIRD APPROACH

The third proposed control structure for compliant control consists of main components shown in Fig. 9 – basic position control loop, impedance controller, fuzzy adaptation mechanism, and neuro-fuzzy classifier which provides for the instantaneous adaptation of the impedance controller according to the type of dynamic environment with which robot maintains contact. In that way this realization represents complex approach uniting concepts proposed in two previous realizations and combining good characteristics they possess.

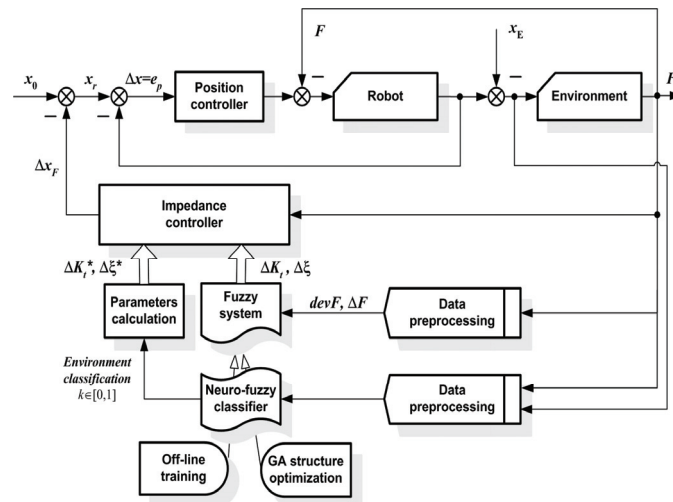

Fig. 9. Block diagram of the third proposed control scheme

Fuzzy adaptation mechanism has the same inputs and outputs as previously. Also, neuro-fuzzy classification of unknown environment is based on the same principles proposed in the previous section.

On the basis of classification initial modifications of the impedance controller ( $\Delta K_i^*$  and  $\Delta \xi_i^*$ ) are calculated by interpolation, which results in initial impedance controller optimal tuning according to the type of environment. Further adaptation of the impedance controller concerning improvement of the transient response, prevention of contact loss and attainment of steady state contact force is performed by the fuzzy adaptation mechanism.

In Fig. 10 simulation experiments for the environment of low stiffness and with efficiency comparison of proposed control structures are presented. Disturbances present in real industrial robotic system have been applied with all tested control realizations – time lags, friction and noises. Steady state force value of  $F_d = 17N$  have been commanded in all cases.

From results it can be concluded that universal impedance control (tuned for the case of most destabilizing environment, line (4) in Fig. 10) demonstrates the worst performance, which is no surprise bearing in mind that such control is tuned for worst environment scenario. It guarantees stable performance in case of unknown environment, but also results in obvious deterioration of performance.

Optimal impedance control (line (3) in Fig. 10), which has been tuned with the assumption that environment is a priori known, demonstrates better performance but that assumption is not realistic. Also, it is not possible to realize the desired a priori unknown steady state contact force with both impedance control realizations.

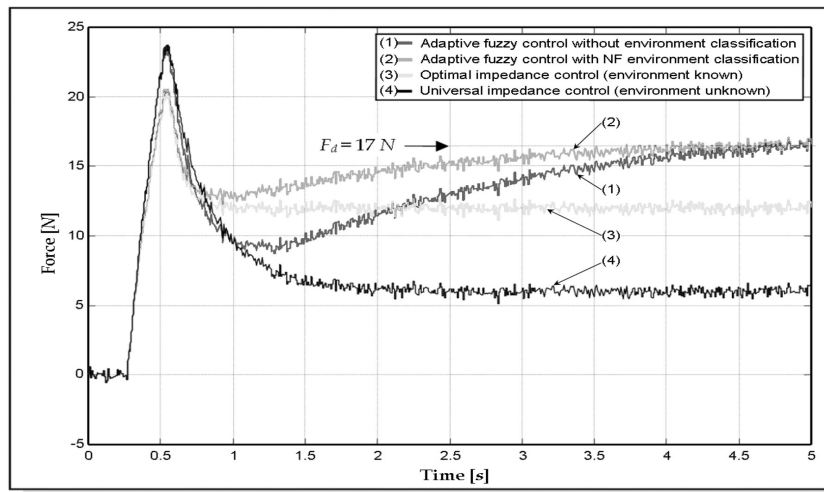

Fig. 10. Comparison of performance of classical impedance control and of proposed adaptive fuzzy schemes

Adaptive fuzzy control without classification (structure from Fig 3., line (1) in Fig. 10) is expectedly superior in comparison to universal impedance control, as it improves the transient performance and maintains desired steady state contact force.

Finally, adaptive fuzzy control with neuro-fuzzy environment classification (structure from Fig 7., line (2) in Fig. 10) has superior performance. Neuro-fuzzy classification selects optimal impedance controller after initial contact, while fuzzy adaptation realizes additional tasks regarding improvement of transition process, prevention of contact loss, and attainment of desired steady state contact force.

## 7. CONCLUSIONS

Proposed compliant motion control schemes, based on the computationally intelligent i.e. neuro-fuzzy-genetic adaptation of the impedance control law, have proven to be efficient in:

- reducing the contact force peak which otherwise occurs in the first phase after the impact,
- preventing the loss of contact under critical task conditions and also
- obtaining desired steady state force.

System is resistant to the presence of sensor noises and friction, and also to moderate presence of time lag.

## REFERENCES

1. Hogan N., Impedance Control: An Approach to Manipulation, Transactions of the ASME, *Journal of Dynamic Systems, Measurement and Control*, Vol. 107, pp. 1-7, 1985.
2. Šurdilović D. et. al, *A Space Robot Control with Advanced Sensor-Based Capabilities: Terrestrial Spin-off*, 27th ISIR, Milano, pp. 243-248, 1996.
3. Šurdilović D., *Contact Transition Stability in the Impedance Control*, Proceedings IEEE Intern. Conf. on Robotics and Automation, Albuquerque, pp. 847-852, 1997.
4. Vukobratović M., Šurdilović D., Control of Robotic Systems in Contact tasks: An Overview, *Izvestia of Control Systems of Russian Academy of Science*, No. 5, pp. 173-192, 1997.
5. Jang R.-S., ANFIS: Adaptive Network based Fuzzy Inference Systems, *IEEE Trans. Syst., Man and Cybern.*, Vol. 23, No. 3, pp. 665-685, 1993.
6. Herrera F., Lozano M., Verdegay J. L., Tackling real-coded genetic algorithms: Operators and tools for behavioral analysis, *Artificial Intell.Rev.*, vol. 12, pp. 265-319, 1998.
7. Šurdilović D., Čojbašić Ž., *Robust Robot Compliant Motion Control Using Intelligent Adaptive Impedance Approach*, 1999 IEEE Int. Conf. on Robotics and Automation ICRA '99, Detroit, Michigan, U.S.A. pp. 2128-2133, 1999.
8. Šurdilović D., Čojbašić Ž., *Robust and Fuzzy Logic Based Adaptive Impedance Control for Stable Robot/Environment Interaction: A Comparative Study*, 3. Branderburger Workshop Mechatronik, Branderburg, Germany, 1998.
9. Kiguchi K, Watanabe K, Izumi K, Fukuda T., *Application of Multiple Fuzzy-Neuro Force Controllers in an Unknown Environment Using Genetic Algorithms*, 2000 IEEE Int. Conference on Robotics and Automation ICRA '2000, San Francisco, U.S.A., pp. 2106-2111, 2000.
10. Katić D., Vukobratović M., A Neural Network-Based Classification of Environment Dynamics Models for Compliant Control of Manipulation Robots, *IEEE Trans. on Syst., Man, and Cybern. - Part B*, vol 28, no. 1, pp.58-69, 1998.
11. Čojbašić Ž., *Development of New Intelligent Adaptive Fuzzy and Hybrid Control Systems*, Ph.D. Thesis, University of Niš, Faculty of Mechanical Engineering, Niš, 2002.
12. Čojbašić Ž., *New approaches to intelligent control of industrial robots in contact tasks*, HIPNEF '2002, Proceedings, pp. 363-369, Vrnjačka Banja, Serbia, 2002.
13. Čojbašić Ž., Nikolić V., Neuro-Fuzzy Environment Classification for Intelligent Robot Compliant Motion Control, *Bulletins for Applied & Computer Mathematics*, Budapest, Hungary, BAM-2024/2002(C), pp. 403-412, 2002.
14. Čojbašić Ž., Nikolić V., Computational Intelligence Filtering Approach for Communications and Control, *Journal of Automatic Control*, Vol XI (2), pp. 73-81, 2002.
15. Čojbašić Ž., Intelligent Hybrid Fuzzy Impedance Approaches for Robot Compliant Motion Control, *Bulletins for Applied & Computer Mathematics*, Budapest, Hungary, BAM-1923/2001(C), pp. 293-302, 2001.

## HIBRIDNO UPRAVLJANJE INDUSTRIJSKIM ROBOTIMA KOD KONTAKTNIH ZADATAKA

**Žarko M. Čojbašić, Vlastimir D. Nikolić**

*U ovom radu razvijene su nove hibridne i računski jednostavne upravljačke šeme za ostvarivanje efikasne interakcije između manipulatora i okoline. Predložena adaptivna neuro-fazi-genetska upravljanja za eksplicitno robotsko upravljanje po sili zasnivaju se na fazi osnaženom konvencionalnom na modelu zasnovanom impedansnom upravljanju industrijskih robota. Simulacije i laboratorijski upravljački eksperimenti sprovedeni na realnom industrijskom robotu sa šest stepeni slobode prikazani su u cilju demonstracije performansi predloženih inteligentnih impedansnih upravljačkih pristupa.*

**Ključne reči:** robotika, impedansno upravljanje, kontakti zadaci, računarska inteligencija, neuro-fazi-genetsko upravljanje